



Clark County Fire Department

FIRE PREVENTION BUREAU

4701 W. Russell Road • Las Vegas, NV 89118



John Steinbeck, Fire Chief

Kelly Blackmon, Sr. Deputy Fire Chief/Fire Marshal

Danny Horvat, Assistant Fire Chief • Wayne Dailey, Assistant Fire Chief

PERMIT GUIDE

TRAFFIC CALMING DEVICES

Common devices for encouraging drivers to slow their speed and thereby reducing the risk of collisions with pedestrians are speed bumps, speed humps and rumble strips. These are regulated on private fire access routes since they affect fire department operations. Traffic calming devices are not permitted on any public roadway in Clark County but may be installed on private fire access routes under this permit type.

APPLICABLE CODES:

Clark County Amendments to the 2018 *International Fire Code* Section 503.4.1 addresses traffic calming devices as follows:

503.4.1 Traffic calming devices. Traffic calming devices shall be prohibited unless approved by the fire code official.

Exceptions:

- 1. Speed humps are allowed on private fire apparatus roads serving commercial and industrial buildings when approved by the fire code official. The location(s), the number permitted, and the design of the speed hump(s) shall meet the approval of the fire code official.**
- 2. Rumble strips are allowed on any private fire apparatus road serving residential, commercial and industrial buildings when approved by the fire code official. A rumble strip must be no higher than 3/4 inch at the highest elevation above the roadway, and a maximum of eight feet in length, as measured along the direction of vehicle travel.**

The fire code official is authorized to require the removal from any private property of any existing traffic management or calming device, including speed bumps that do not meet the applicable criteria, and has been determined by the fire code official to unnecessarily hinder emergency apparatus response.

Examples of speed humps and rumble strips are given on the last page of this guide.

SUBMITTAL REQUIREMENTS:

Provide a diagram that is either drawn to scale or show dimensions of the fire access lane and the proposed location(s) of the traffic calming device(s). Also state the type of device to be installed (speed hump or rumble strip).

BOARD OF COUNTY COMMISSIONERS

JAMES B. GIBSON, Chair • JUSTIN C. JONES, Vice Chair
MARILYN KIRKPATRICK • WILLIAM MCCURDY II • ROSS MILLER • MICHAEL NAFT • TICK SEGERBLOM
KEVIN SCHILLER, County Manager

EXAMPLE SPEED HUMP AND RUMBLE STRIP

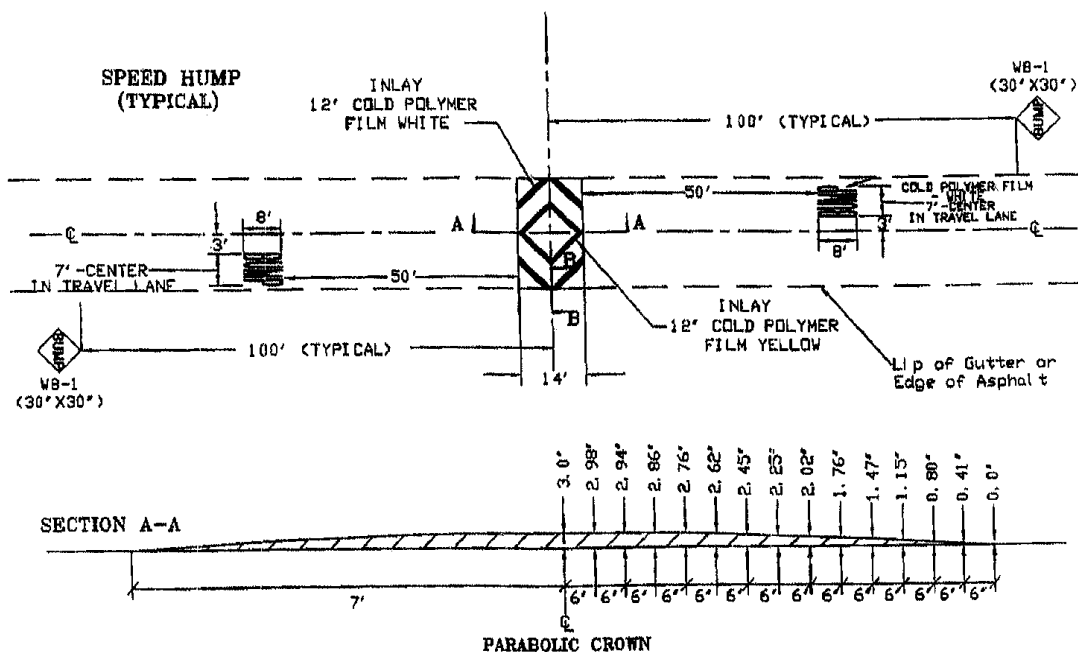

CLARK COUNTY FIRE DEPARTMENT SPEED HUMP EXAMPLE

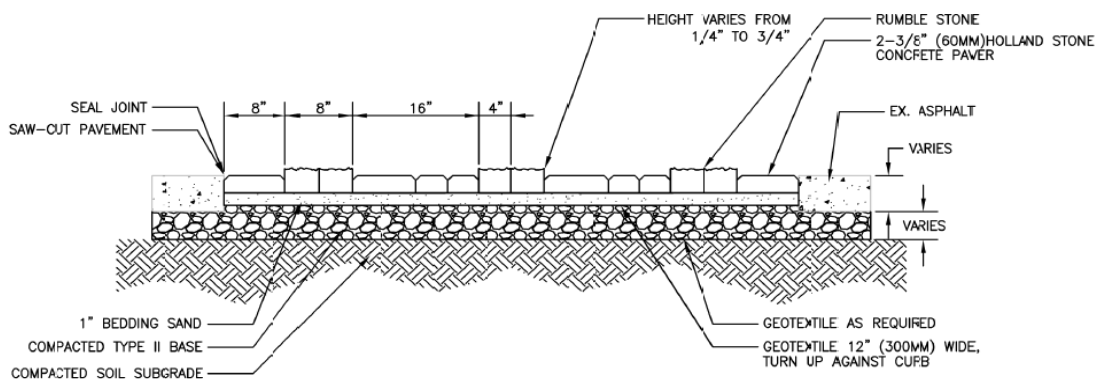

NOTES:

1. LOW PROFILE TRAFFIC CALMING DEVICE DESIGNED TO REDUCE EXCESSIVE SPEEDS AND NOTIFY DRIVERS OF IMPENDING CHANGES IN TRAFFIC CONDITIONS SUCH AS STOP SIGNS, INTERSECTIONS, OR CROSSWALKS.
2. BASE THICKNESS DETERMINED BY THICKNESS OF EXISTING ASPHALT ALONG WITH TRAFFIC, CLIMATE, AND SUB-GRADE CONDITIONS.
3. THIS DETAIL IS NOT RECOMMENDED FOR OTHER THAN LCW VOLUME RESIDENTIAL STREETS WITH A POSTED SPEED LIMIT OF 25 MPH OR LESS.